

The Benefits of Being Erratic:

Correcting Errors with Noise-Enhanced Gradient Algorithms

Chris Winstead, Tasnuva Tithi (Utah State University)
Emmanuel Boutillon (Lab-STICC, Université de Bretagne Sud)
Fakhreddine Ghaffari (ETIS Lab, Université Cergy-Pontoise)



November 2017

Outline

- ▶ **Noise enhancement** is a recently studied effect in error correction algorithms, especially **low-density parity-check (LDPC) codes**.
- ▶ We interpret noise as a form of **algorithm diversity**.

Outline

- ▶ **Noise enhancement** is a recently studied effect in error correction algorithms, especially **low-density parity-check (LDPC) codes**.
- ▶ We interpret noise as a form of **algorithm diversity**.
 - ▶ **Noise is analyzable** using statistical methods, but. . .

Outline

- ▶ **Noise enhancement** is a recently studied effect in error correction algorithms, especially **low-density parity-check (LDPC) codes**.
- ▶ We interpret noise as a form of **algorithm diversity**.
 - ▶ **Noise is analyzable** using statistical methods, but. . .
 - ▶ Noise can be complex to produce;

Outline

- ▶ **Noise enhancement** is a recently studied effect in error correction algorithms, especially **low-density parity-check (LDPC) codes**.
- ▶ We interpret noise as a form of **algorithm diversity**.
 - ▶ **Noise is analyzable** using statistical methods, but. . .
 - ▶ Noise can be complex to produce;
 - ▶ Simpler procedures can supply the required diversity.

Outline

- ▶ **Noise enhancement** is a recently studied effect in error correction algorithms, especially **low-density parity-check (LDPC) codes**.
- ▶ We interpret noise as a form of **algorithm diversity**.
 - ▶ **Noise is analyzable** using statistical methods, but. . .
 - ▶ Noise can be complex to produce;
 - ▶ Simpler procedures can supply the required diversity.
- ▶ New results on diversity approaches:

Outline

- ▶ **Noise enhancement** is a recently studied effect in error correction algorithms, especially **low-density parity-check (LDPC) codes**.
- ▶ We interpret noise as a form of **algorithm diversity**.
 - ▶ **Noise is analyzable** using statistical methods, but. . .
 - ▶ Noise can be complex to produce;
 - ▶ Simpler procedures can supply the required diversity.
- ▶ New results on diversity approaches:
 - ▶ Simpler periodic perturbations

Outline

- ▶ **Noise enhancement** is a recently studied effect in error correction algorithms, especially **low-density parity-check (LDPC) codes**.
- ▶ We interpret noise as a form of **algorithm diversity**.
 - ▶ **Noise is analyzable** using statistical methods, but. . .
 - ▶ Noise can be complex to produce;
 - ▶ Simpler procedures can supply the required diversity.
- ▶ New results on diversity approaches:
 - ▶ Simpler periodic perturbations
 - ▶ Parity-only bit flipping

Outline

- ▶ **Noise enhancement** is a recently studied effect in error correction algorithms, especially **low-density parity-check (LDPC) codes**.
- ▶ We interpret noise as a form of **algorithm diversity**.
 - ▶ **Noise is analyzable** using statistical methods, but. . .
 - ▶ Noise can be complex to produce;
 - ▶ Simpler procedures can supply the required diversity.
- ▶ New results on diversity approaches:
 - ▶ Simpler periodic perturbations
 - ▶ Parity-only bit flipping
 - ▶ Threshold sequences tailored to dominant trapping sets.

Introduction

LDPC codes are a class of large-frame error correcting code defined by a constraint graph or Tanner graph.

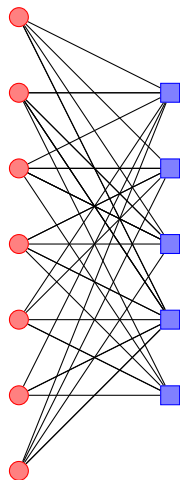

Introduction

LDPC codes are a class of large-frame error correcting code defined by a constraint graph or Tanner graph.

The graph's **variables** are binary bits in a data frame.

variables

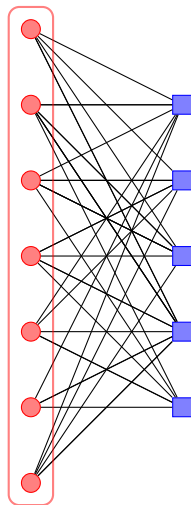

Introduction

LDPC codes are a class of large-frame error correcting code defined by a constraint graph or Tanner graph.

The graph's **variables** are binary bits in a data frame.

The graph's **parity-checks** constrain even parity among adjacent bits.

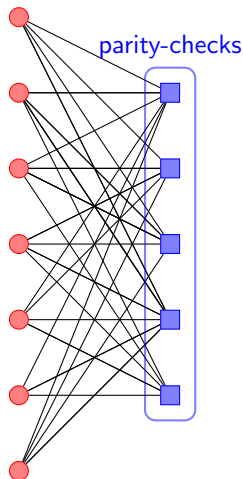

Introduction

The goal of decoding is to obtain the *most probable* bit values that satisfy all of the parity-check constraints.

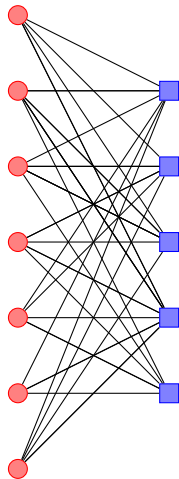

Introduction

The goal of decoding is to obtain the *most probable* bit values that satisfy all of the parity-check constraints.

This problem is usually modeled as a **Bayesian Belief Network**, using the **Belief Propagation (BP)** algorithm. Probability calculations can be expensive, and **cycles in the network** distort the calculations, leading to failures.

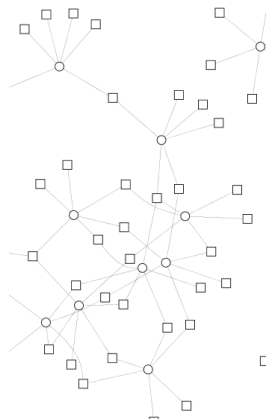

Trapping Sets

Trapping sets or Absorbing Sets are repeated cyclic patterns in the code graph.

They induce **error floors** in LDPC decoders based on BP.

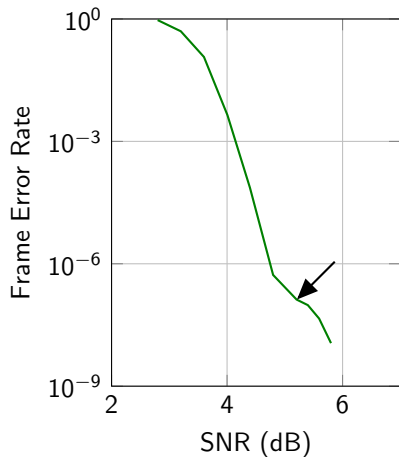
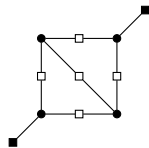
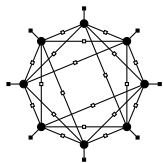

FAIDs & Decoder Diversity

There are many approaches for dealing with absorbing sets.

The general framework of **Finite Alphabet Iterative Decoders (FAID)** describes a class of decoders by LUTs rather than explicit Bayesian calculations^a.

Any particular FAID has small error coverage, but **decoder diversity** guarantees total coverage by alternating between different LUTs.

^aPlanjery et al. 2013; Declercq et al. 2013.

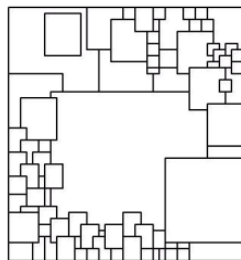
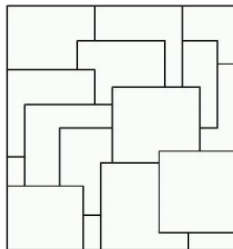

Single-Bit Algorithms

Several classes of low-complexity algorithms have been studied. Some notable algorithms:

- ▶ **Stochastic Decoding**¹ – Emulate BP using stochastic arithmetic.

¹Gaudet and Rapley 2003.

²Winstead and Boutillon 2014.

³Mobini and Hemati 2009.

Single-Bit Algorithms

Several classes of low-complexity algorithms have been studied. Some notable algorithms:

- ▶ **Stochastic Decoding**¹ – Emulate BP using stochastic arithmetic.
- ▶ **Maximum Likelihood Single-Bit Message (MLSBM)**² – Similar to FAID, formal procedure to design LUTs.

¹Gaudet and Rapley 2003.

²Winstead and Boutillon 2014.

³Mobini and Hemati 2009.

Single-Bit Algorithms

Several classes of low-complexity algorithms have been studied. Some notable algorithms:

- ▶ **Stochastic Decoding**¹ – Emulate BP using stochastic arithmetic.
- ▶ **Maximum Likelihood Single-Bit Message (MLSBM)**² – Similar to FAID, formal procedure to design LUTs.
- ▶ **Differential Decoding w/ Binary Message Passing (DD-BMP)**³ – Uses a memory effect inspired by relaxation algorithms.

¹Gaudet and Rapley 2003.

²Winstead and Boutillon 2014.

³Mobini and Hemati 2009.

Single-Bit Algorithms

Several classes of low-complexity algorithms have been studied. Some notable algorithms:

- ▶ **Stochastic Decoding**¹ – Emulate BP using stochastic arithmetic.
- ▶ **Maximum Likelihood Single-Bit Message (MLSBM)**² – Similar to FAID, formal procedure to design LUTs.
- ▶ **Differential Decoding w/ Binary Message Passing (DD-BMP)**³ – Uses a memory effect inspired by relaxation algorithms.
- ▶ **Bit-Flipping** – Heuristics *loosely based* on BP or gradient descent.

¹Gaudet and Rapley 2003.

²Winstead and Boutillon 2014.

³Mobini and Hemati 2009.

Parallel Bit-Flipping Decoders

A binary alternative, simpler than BP or Stochastic decoders.

Inputs

channel sample y_i .
hypothesis $x_i \in \{-1, +1\}$.
parity checks $s_j \in \{-1, +1\}$

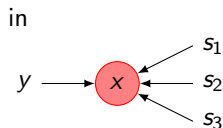

Operations

Reliability metric: Δ_i (unique to algorithm)
Threshold update: flip x_i if $\Delta_i \leq \theta$

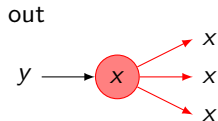

Then transmit x_i to adjacent nodes.

Example Algorithms

Impr. Diff. Binary (IDB):⁴ $\Delta_i^{(t+1)} = \Delta_i^{(t)} + w \sum_{j \in \mathcal{M}_i \setminus \mathcal{J}} s_{i,j} - d x_i^{(t)}$

Grad. Desc. BF (GDBF):⁵ $\Delta_i^{(t+1)} = x_i y_i + \sum_j s_j$

Noisy GDBF:⁶ $\Delta_i^{(t+1)} = x_i y_i + w \sum_j s_j + q$

Probabilistic GDBF:⁷ If $\Delta_i < \theta$, flip with probability p .

Traditional rule of thumb: higher complexity = better performance.

⁴Cushon et al. 2014.

⁵Wadayama et al. 2008.

⁶Sundararajan, Winstead, and Boutillon 2014.

⁷Rasheed, Ivanis, and Vasic 2014.

Motivation: Reduced Complexity

Standard BP-based or FAID algorithm:

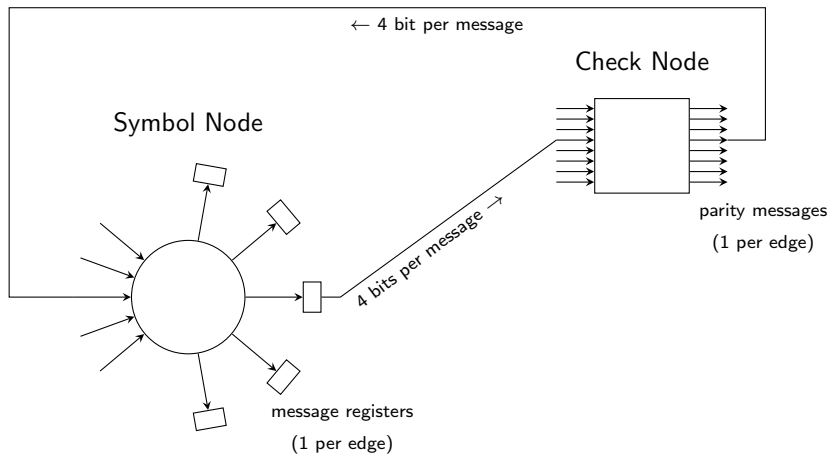

Motivation: Reduced Complexity

Stochastic algorithm (successive relaxation):

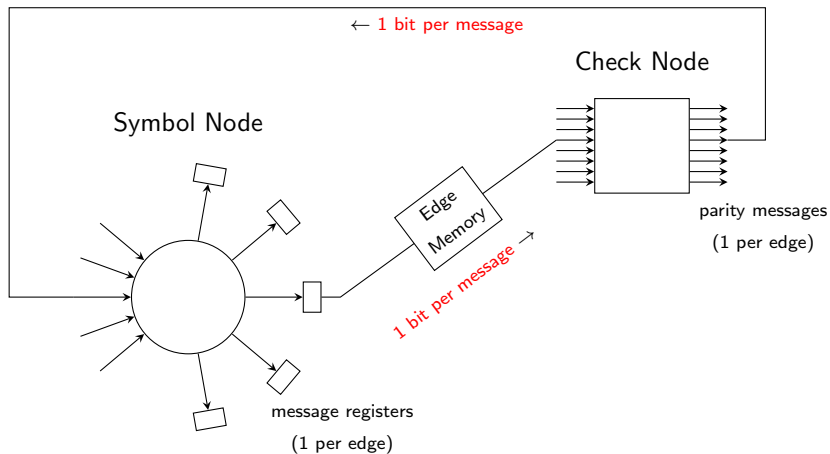

Motivation: Reduced Complexity

Bit-flipping algorithm:

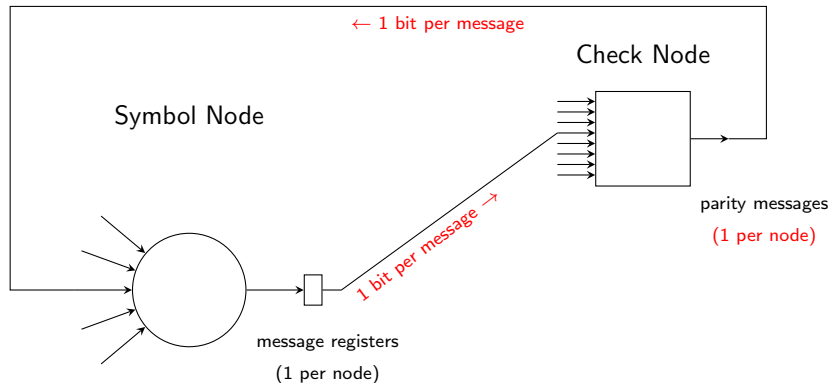

Example Node Designs

NGDBF

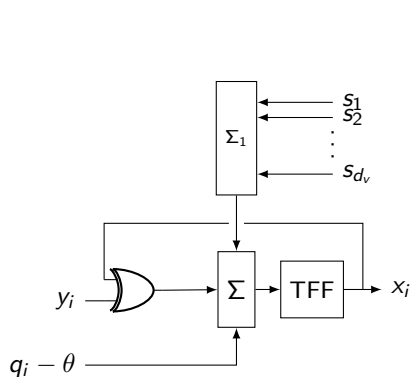

IDB

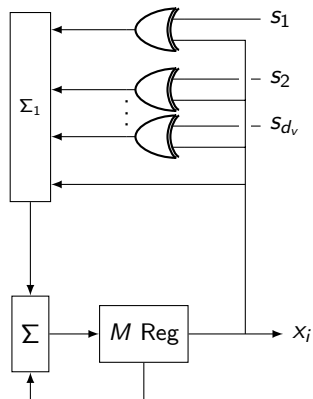

Performance: Noise Enhancement

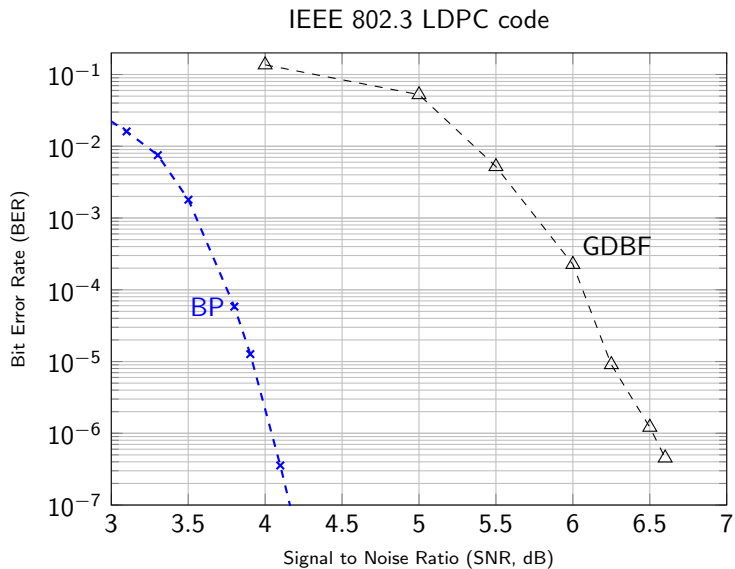

Performance: Noise Enhancement

IEEE 802.3 LDPC code

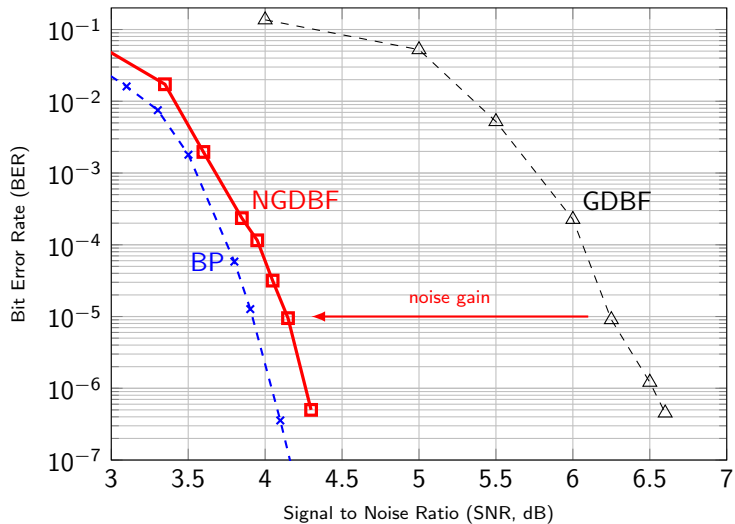

PGDBF FER

FAID and PGDBF approach Maximum Likelihood (ML) limit⁸

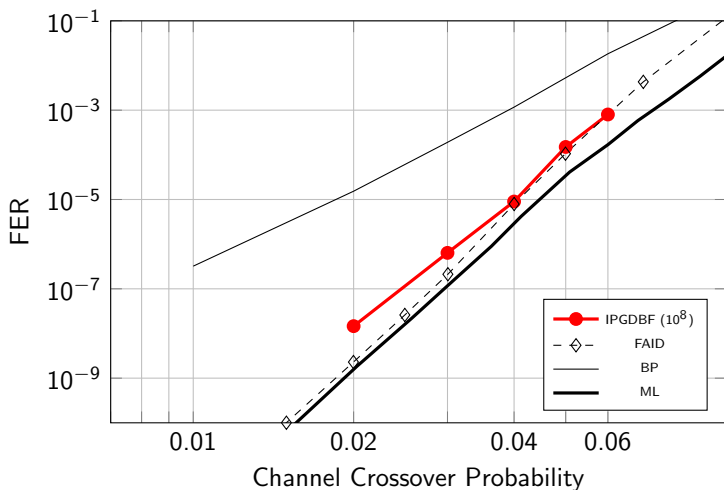

⁸Declercq et al. 2016.

We know that noise works...

Treating each trapping set as a Markov process, we can predict the error rate and optimize algorithm parameters:

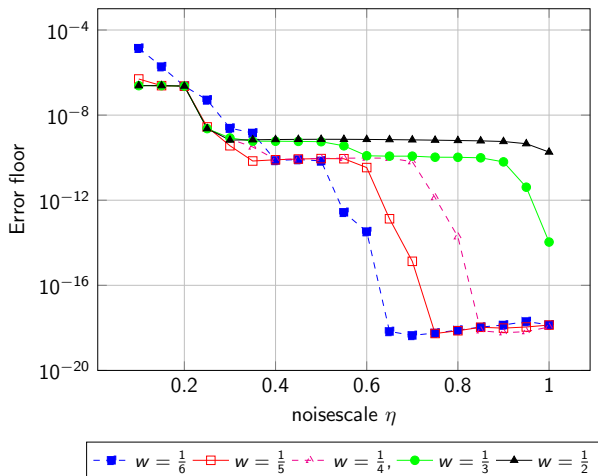

What is the bigger picture? *Why* does non-determinism enhance these algorithms?

Parrondo's "paradox"

Parrondo's paradox considers noise-perturbed particles on various sloped surfaces. These are "failing" strategies:⁹

Parrondo's "paradox"

But by alternating between losing strategies at the right times, and with the right amount of noise energy, it's possible to "win" with high probability:

Diversity in Parrondo's Ratchet

- ▶ Parrondo's paradox is an example of algorithmic diversity.

Diversity in Parrondo's Ratchet

- ▶ Parrondo's paradox is an example of algorithmic diversity.
- ▶ Noise is important to the demonstration only as another source of diversity – it could be replaced by additional strategies.

Diversity in Parrondo's Ratchet

- ▶ Parrondo's paradox is an example of algorithmic diversity.
- ▶ Noise is important to the demonstration only as another source of diversity – it could be replaced by additional strategies.
- ▶ Bit-flipping algorithms are “losers,” and noise turns them into “winners” . . .

Diversity in Parrondo's Ratchet

- ▶ Parrondo's paradox is an example of algorithmic diversity.
- ▶ Noise is important to the demonstration only as another source of diversity – it could be replaced by additional strategies.
- ▶ Bit-flipping algorithms are “losers,” and noise turns them into “winners” . . .
- ▶ But maybe there are other ways to achieve this diversity.

Lowering the Error Floor

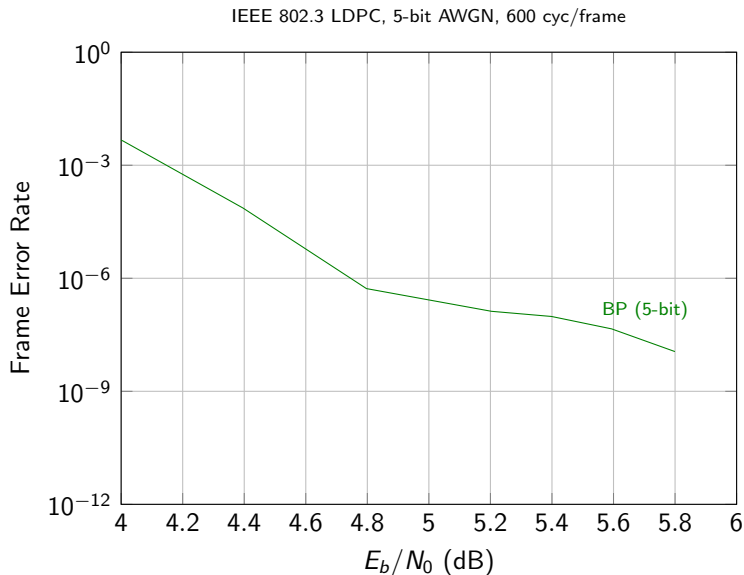

Lowering the Error Floor

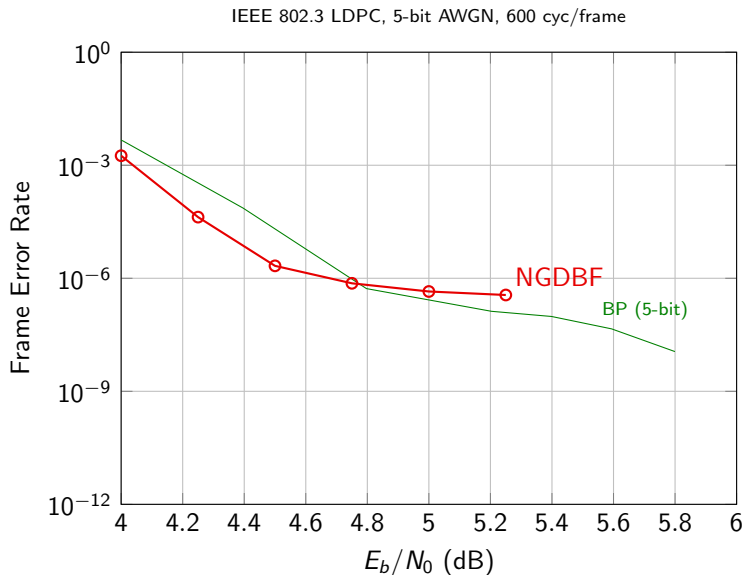

Lowering the Error Floor

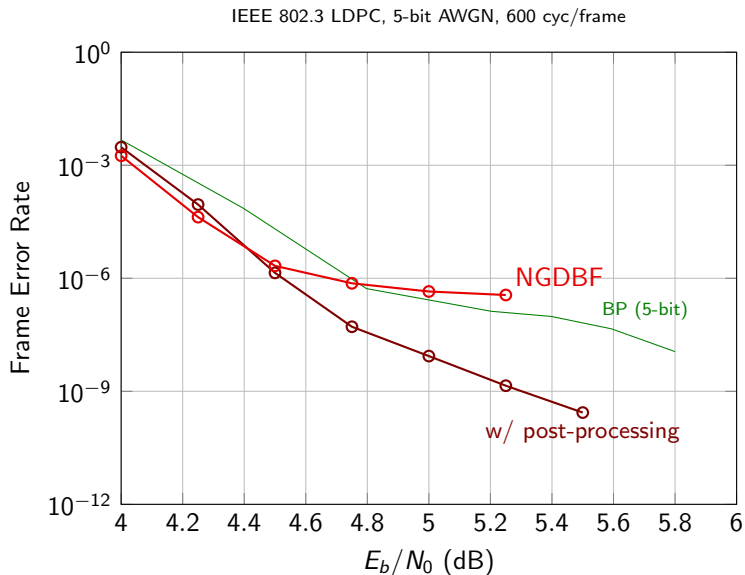

Lowering the Error Floor

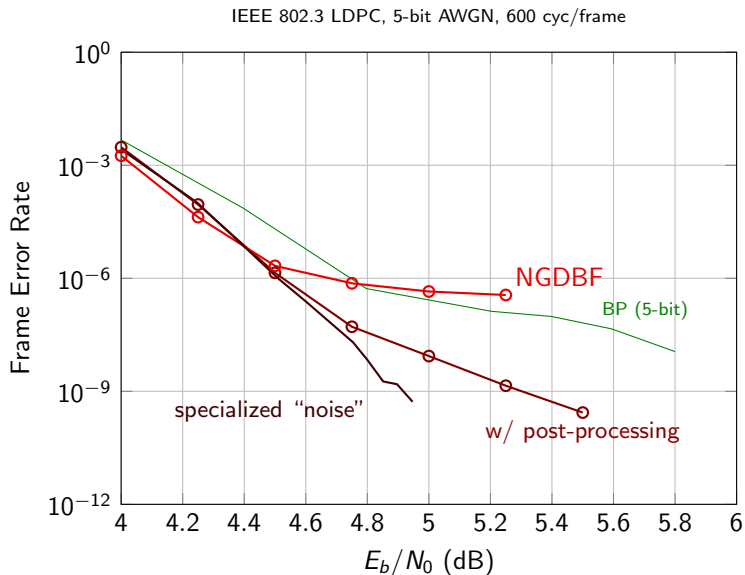

Discussion

- ▶ The error floor is steadily disappearing. . .

Discussion

- ▶ The error floor is steadily disappearing. . .
- ▶ Each improvement simultaneously reduces implementation complexity while enhancing performance.

Discussion

- ▶ The error floor is steadily disappearing. . .
- ▶ Each improvement simultaneously reduces implementation complexity while enhancing performance.
- ▶ We now have a basic theory to explain and optimize noise enhancement.

Discussion





- ▶ The error floor is steadily disappearing. . .
- ▶ Each improvement simultaneously reduces implementation complexity while enhancing performance.
- ▶ We now have a basic theory to explain and optimize noise enhancement.
- ▶ Algorithm diversity remains an open frontier.

Acknowledgements





This research was supported by the US **National Science Foundation** under award ECCS-0954747, and by the **Franco-American Fulbright Commission** for the international exchange of scholars, and by the French **Agence Nationale de la Recherche (ANR)** under award ANR-15-CE25-0006-01.



References I

-  Planjery, S. K. et al. (2013). "Finite Alphabet Iterative Decoders Part I: Decoding Beyond Belief Propagation on the Binary Symmetric Channel". In: *IEEE Trans. Comm.* DOI: [10.1109/TCOMM.2013.090513.120443](https://doi.org/10.1109/TCOMM.2013.090513.120443).
-  Declercq, D. et al. (2013). "Finite Alphabet Iterative Decoders Part II: Towards Guaranteed Error Correction of LDPC Codes via Iterative Decoder Diversity". In: *IEEE Trans. Comm.* DOI: [10.1109/TCOMM.2013.090513.120444](https://doi.org/10.1109/TCOMM.2013.090513.120444).
-  Gaudet and Rapley (2003). "Iterative decoding using stochastic computation". In: *Electronics Letters*.
-  Winstead and Boutillon (2014). "Decoding LDPC Codes With Locally Maximum-Likelihood Binary Messages". In: *IEEE Comm. Lett.*
-  Mobini, Banihashemi and Hemati (2009). "A differential binary message-passing LDPC decoder". In: *IEEE Trans. Comm.* DOI: [10.1109/TCOMM.2009.09.070617](https://doi.org/10.1109/TCOMM.2009.09.070617).

References II

-  Cushon, K. et al. (2014). “High-Throughput Energy-Efficient LDPC Decoders Using Differential Binary Message Passing”. In: *Signal Processing, IEEE Transactions on* 62.3, pp. 619–631. ISSN: 1053-587X. DOI: 10.1109/TSP.2013.2293116.
-  Wadayama, T. et al. (2008). “Gradient descent bit flipping algorithms for decoding LDPC codes”. In: *Information Theory and Its Applications, 2008. ISITA 2008. International Symposium on*, pp. 1 –6. DOI: 10.1109/ISITA.2008.4895387.
-  Sundararajan, Gopalakrishnan, Chris Winstead, and Emmanuel Boutillon (2014). *Noisy Gradient Descent Bit-Flip Decoding for LDPC Codes*. arXiv:1402.2773. URL: <http://arxiv.org/abs/1402.2773>.
-  Rasheed, O.-A., P. Ivanis, and B. Vasic (2014). “Fault-Tolerant Probabilistic Gradient-Descent Bit Flipping Decoders”. In: *IEEE Commun. Letters* 18.9, pp. 1487 –1490.
-  Declercq, David et al. (2016). “Noise-aided gradient descent bit-flipping decoders approaching maximum likelihood decoding”. In: *IEEE ISTC*.

References III



Parrondo, Juan MR, Gregory P Harmer, and Derek Abbott (2000). “New paradoxical games based on Brownian ratchets”. In: *Physical Review Letters* 85.24, p. 5226.